

LPG RECOVERY PLANT – GASSI TOUIL COMPLEX Sahara Desert, Algeria – REPSOL EXPLORACIÓN ARGELIA

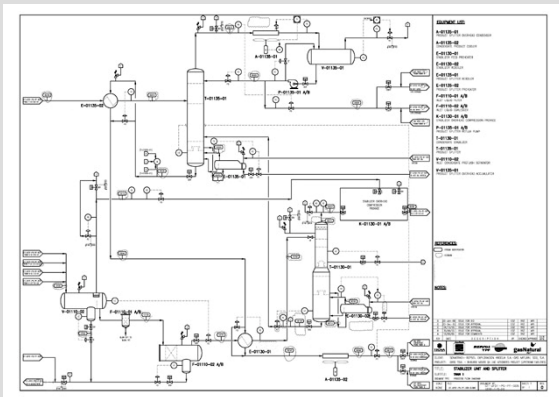
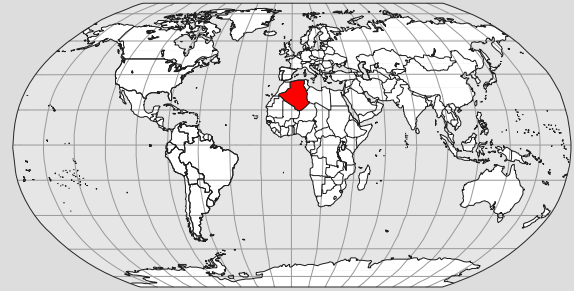
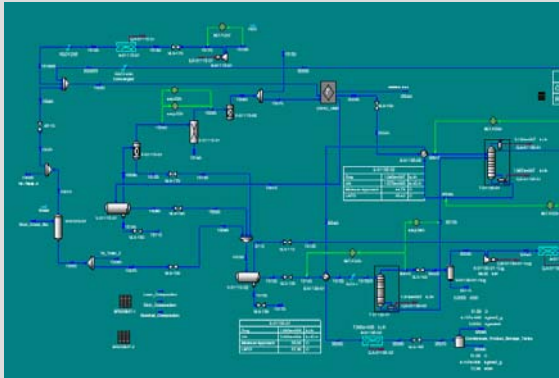

Main Facts

- **Gas Processing Capacity:**
17 MMSCMD (600 MMSCFD)
- **Liquids Processing Capacity:**
4,270 m³/d (26,850 bpd)
- **Schedule:** June 2005 – March 2006
(10 months)

Scope

- LPG Technology Screening
- Conceptual Engineering
- Design Philosophies Development
(whole Gassi Touil Complex)
- Front End Engineering Design (FEED)
- HAZID & HAZOP Assistance
- Long Lead Items Requisitions
- Material Take Off

Facilities

- Receiving Facilities: Slug Catcher
- NGL Recovery (Turboexpansion)
2 Trains
- Condensate Stabilization and LPG
Fractionation – 2 Trains
- Residue Gas Compression – 2 Trains
- Utilities (waste heat recovery, heating oil,
flare system, etc.)

Highlights

- Extensive NGL recovery technologies
screening, considering different
Licensors and recently built plants
- Gassi Touil Complex also includes
Amine Sweetening, CO₂ Injection and
TEG Dehydration plants (flare system,
tie-ins, electrical distribution, control
system architecture & lay out developed
considering whole complex)
- In-depth materials selection and
corrosion studies
- Optimization of vent systems capacities
& flares lay out (plant had 4 flares)

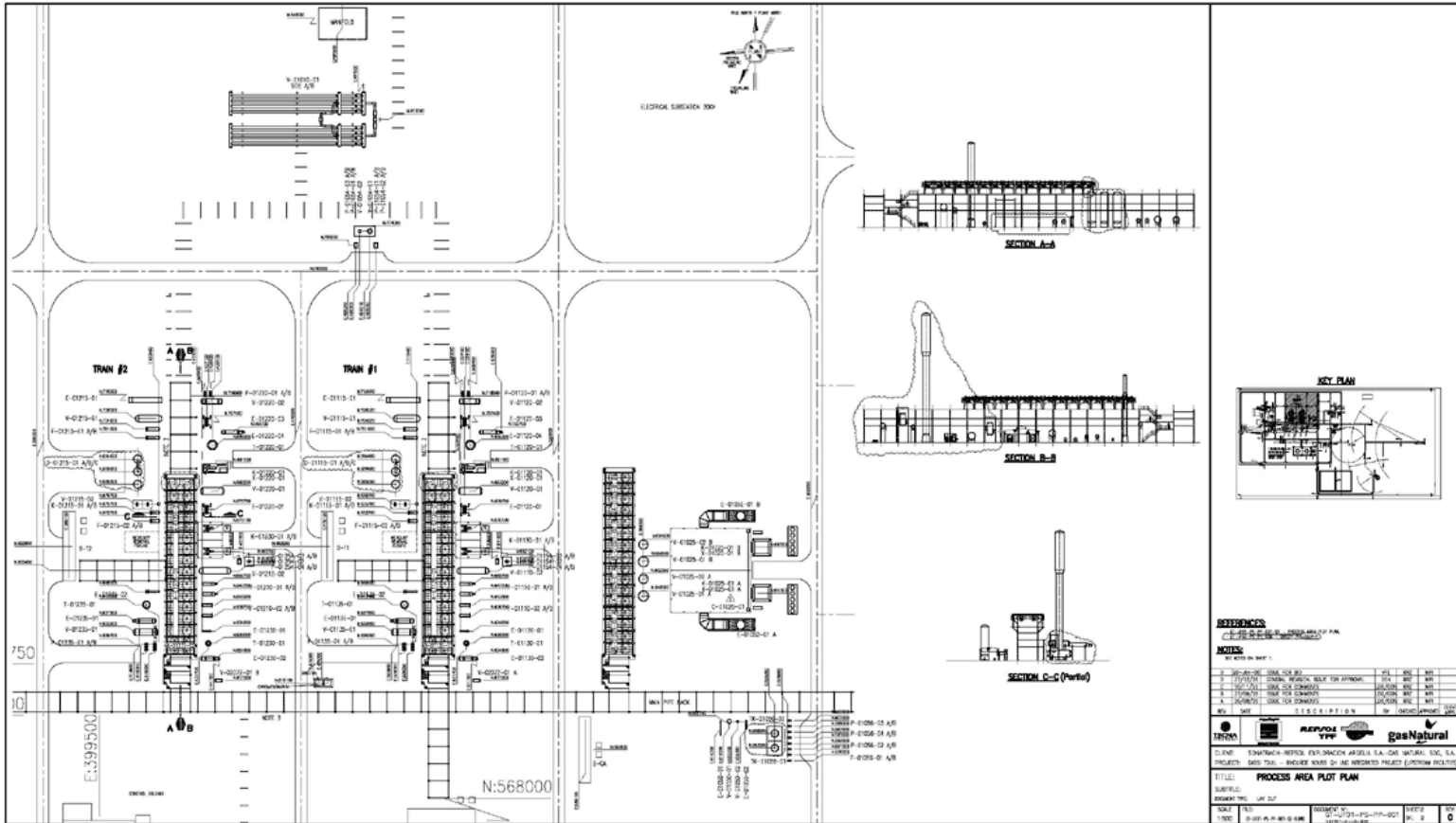

GASSI TOUIL COMPLEX – LPG RECOVERY PLANT – SAHARA DESERT, ALGERIA – REPSOL EXPLORACIÓN ARGELIA S.A.

ARGENTINA

Encarnación Ezcurra 365
C1107CLA Buenos Aires
Ph.: +54 (11) 4347 0300

BOLIVIA

Torres CAINCO
Av. Las Américas 7 - Piso 10
Santa Cruz de la Sierra
Ph.: +591 (3) 336 2263

BRAZIL

Rio Office Park - Av. Victor Civita 77
Bloco 1, Edif. 6.2, 6° andar
22775-044 Barra da Tijuca
Rio de Janeiro (RJ)
Ph.: +55 (21) 3535-9855
Fax: +55 (21) 3535-9887

COLOMBIA

Calle 99 No. 9A - 45 Oficina 303 A
Barrio Chicó, Bogotá DC
Ph.: +57 (1) 745 8069
Fax: +57 (1) 745 8077

ECUADOR

Av. República de El Salvador 780
Edificio Twin Towers - Piso 6 - Quito
Ph.: +593 (2) 292 3943

MEXICO

Paseo de la Reforma 373 - Piso 14
Col. Cuauhtemoc, México D.F
Ph.: +52 (555) 207 2625

PERU

Av. Canaval y Moreyra N° 452,
Oficina 1401, San Isidro, Lima 27
Ph.: +(511) 705 3070

SAUDI ARABIA

P.O.Box 3865
Al Falak Towers, 5th.Floor
King Abdulaziz Road
Al Khobar 31952- KSA
Ph.: +966 (3) 887 5339

SPAIN

Av. del General Perón 38,
Edificio MASTER's 1 - Planta 13
28020, Madrid
Ph.: +34 (91) 556 6359 / 6751

USA

2500 City West Boulevard,
Suite 300
Houston, Texas
Ph.: +1 (713) 405 1836

VENEZUELA

Quinta Zamira, Sede EPSA,
Urbanización Chuao, Municipio Baruta,
Caracas, Venezuela
Ph.: +58 (212) 993 2215 / 3588